



# 16 Port Gigabit Unmanaged Ethernet Switch

Tech Support # 833-574-9124  
info@wboxtech.com



wboxtech.com



0E-16PGIGUN



8 40049130658 5

Tech Support # 833-574-9124  
info@wboxtech.com



The 16 Port Gigabit Unmanaged Ethernet Switch is designed for many applications such as small home offices, internet cafes, schools, and small/medium enterprises. A Full Gigabit Ethernet Switch that is designed to upgrade to Gigabit and meet High Bandwidth Requirements, this switch provides 16 10/100/1000 Mbps Adaptive Ethernet Ports. All Ports support full line speed, non-blocking switching and port auto flips functionality.

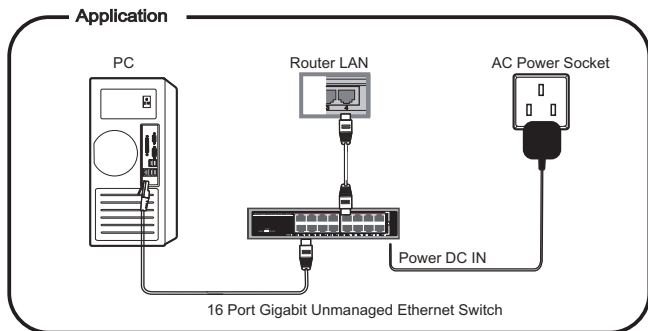

## Feature

- Conforms to IEEE 802.3, IEEE 802.3u, IEEE 802.3ab
  - Provides 16 10/100/1000 Base-T ports
  - High back-plane bandwidth 32 Gbps
  - IEEE 802.3x Flow control
  - The switch supports one-key function conversion, currently supports three modes, DEFAULT mode, VLAN mode, EXTEND 820 ft (250 meters) mode
- DEFAULT mode: no special function
- VLAN : Port 1-14 will not communicate with each other and only communicate with Port 15-16.
- It provides better control over network storms, assuring data/information flow security
- EXTEND 820 ft (250 meters): The speed of Port 1-14 will slow down to 10 Mbps, allowing data transfer up to 820 ft (250 meters)



## Notice

The transmission distance is related to the connected cable. Standard Cat5e/6 network cable and the quality of camera will help maximize the furthest distance possible

If any W Box Technologies product is found to be in good working order or such product's inability to function properly is a result of user damage or abuse, the product will be returned to Buyer in the same condition as received and Buyer shall be responsible for any return freight changes.

## 5. Governing Law

For North America – The laws of State of New York apply to this Limited Warranty.

For EMEA – This Limited Warranty shall be governed by the laws of England and Wales.

## 6. Miscellaneous

Where any term of this Limited Warranty is prohibited by such laws, it shall be null and void, but the remainder of the Limited Warranty shall remain in full force and effect.

## Board Diagram

16 Port Gigabit Unmanaged Ethernet Switch

### Front

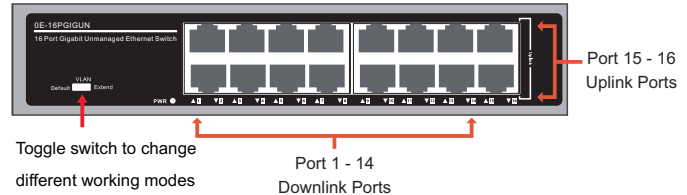

### Back



## Installation Steps

Please check the following items before installation. If any items are missing, please contact ADI or the installing company.

● 16 Port Gigabit Unmanaged Ethernet Switch	1pc
● AC power cable	1pc
● Screws	4pcs
● Bracket for 19" Rack	2pcs
● User manual	1pc

### Please follow the below installation steps

- 1) Please turn off the power signal and the display devices power before installation. Please note: Installing with the power on will damage the equipment
- 2) Use network cable to connect the PC or other wired equipment that needs to be on the provided equipment
- 3) Use a network cable connect equipment up link to port and Router LAN
- 4) Connect the power adapter
- 5) Check if the installation is correct, the equipment is in good condition and the connection is stable; then connect power to the system
- 6) Ensure the Ethernet equipment has power and is working properly.

## Specification

Item		Description	
Power	Power Supply	Built-in power supply	
	Voltage Range	AC100~ 240V	
	Consumption	<15W	
Ethernet	Speed	Port 1-16: 10/100/1000 Mbps	
	Transmission Distance	Port 1-14 820 ft (250 meters) with 10 Mbps, Port 15-16 328 ft (100 meters) with 10/100/1000 Mbps	
Network Switch	Ethernet Standard	IEEE 802.3 / 802.3u / 802.3ab	
	Switching capacity	32G	
	Transfer Rate	14,880 pps for 10 Mbps 148,800 pps for 100 Mbps 1,488,000 pps for 1000 Mbps	
	MAC Address	8K MAC address table	
LINK/ACT	On	Green	The port is connecting
	Blinks	-	The port is receiving or transmitting data
	Off	-	The port is not linked successfully with the device
Working Environment	Working Temperature	0~40℃ (32~ 104 Deg. F)	
	Storage Temperature	-40~70℃ (-40~158 Deg. F)	
	Humidity Non condensing	0~85%	
Mechanical	Dimension L * W * H	7.87"x4.65"x1.73"	
		200 x 118 x 44mm	
	Color	Black	

Specifications are subject to change without prior notice

### 3. Limitation on Liability to Buyer's Customers.

Buyer agrees to limit liability to its customers to the fullest extent permitted by law. Buyer acknowledges that ADI shall only be deemed to give consumers of its products such statutory warranties as may be required by law and at no time shall Buyer represent to its customers and/or users of ADI products that ADI provides any additional warranties. By accepting the products, to the fullest extent permitted by law, Buyer assumes all liability for, and agrees to indemnify and hold ADI harmless against and defend ADI from, any and all suits, claims, demands, causes of action and judgments relating to damages, whether for personal injury or to personal property, suffered by any person, firm, corporation or business association, including but not limited to, Buyer's customers and/or users of the products because of any failure of the products to detect and/or warn of the danger for which the goods were designed or any other failure of the products whether or not such damages are caused or contributed to by the sold or joint concurring negligence or fault of ADI.

### 4. Returns

Subject to the terms and conditions listed below, during the applicable warranty period, ADI will replace Product or provide a credit at purchase at its sole option free of charge any defective products returned prepaid. Any obligations of ADI to replace Limited Lifetime warranty products pursuant to this warranty which result from defect are limited to the availability of replacement product. ADI reserves the right to replace any such products with the then currently available products, or provide a credit in its sole discretion. In the event Buyer has a problem with any ADI product, please call your local ADI branch for return instructions:

For US call 1-800-233-6261

For Canada call 877-234-7378

For Puerto Rico call 787-793-8830

For EMEA contact your local ADI Branch

Be sure to have the model number and the nature of the problem available. In the event of replacement, the return product will be credited to Buyer's account and a new invoice issued for the replacement item. ADI reserves the right to issue a credit only in lieu of replacement.

## 2. EXCLUSION OF WARRANTIES, LIMITATION OF LIABILITY

THERE ARE NO WARRANTIES OR CONDITIONS, EXPRESS OR IMPLIED, OF MERCHANTABILITY, OR FITNESS FOR A PARTICULAR PURPOSE OR OTHERWISE, WHICH EXTEND BEYOND THE DESCRIPTION ON THE FACE HEREOF. TO THE FULLEST EXTENT PERMITTED BY LAW, IN NO CASE SHALL ADI BE LIABLE TO ANYONE FOR ANY (I) CONSEQUENTIAL, INCIDENTAL, INDIRECT, SPECIAL, OR PUNITIVE DAMAGES ARISING OUT OF OR RELATING IN ANY WAY TO THE PRODUCT AND/OR FOR BREACH OF THIS OR ANY OTHER WARRANTY OR CONDITION, EXPRESS OR IMPLIED, OR UPON ANY OTHER BASIS OF LIABILITY WHATSOEVER, EVEN IF THE LOSS OR DAMAGE IS CAUSED BY ADI'S OWN NEGLIGENCE OR FAULT AND EVEN IF ADI HAS BEEN ADVISED OF THE POSSIBILITY OF SUCH LOSSES OR DAMAGES. Any product description (whether in writing or made orally by ADI or ADI's agents), specifications, samples, models, bulletin, drawings, diagrams, engineering sheets, or similar materials used in connection with the Buyer's order are for the sole purpose of identifying ADI's products and shall not be construed as an express warranty or condition. Any suggestions by ADI or ADI's agents regarding use, applications or suitability of the products shall not be construed as an express warranty or condition unless confirmed to be such in writing by ADI. ADI does not represent that the products it sells may not be compromised or circumvented; that the products will prevent any personal injury or property loss by burglary, robbery, fire or otherwise, or that the products will in all cases provide adequate warning or protection. Buyer understands and will cause its customer to understand that a properly installed and maintained product is not insurance or guarantee that such will not cause or lead to personal injury or property loss. CONSEQUENTLY ADI SHALL HAVE NO LIABILITY FOR ANY PERSONAL INJURY, PROPERTY DAMAGE OR OTHER LOSS BASED ON ANY CLAIM AT ALL INCLUDING A CLAIM THAT THE PRODUCT FAILED TO GIVE WARNING. However, if ADI is held liable whether directly or indirectly for any loss or damage with respect to the products it sells, regardless of cause or origin, its maximum liability shall not in any case exceed the purchase price of the product, which shall be fixed as liquidated damages and not as a penalty and shall be the complete and exclusive remedy against ADI.

## Trouble Shooting

- Make sure the equipment is installed according to the Manufacturer's installation guide
- Confirm RJ45 cable order meets EIA/TIA 568A or 568B standard.
- Replace the equipment with a proper functioning 16 Port Network Switch to check if the equipment is damaged.
- Please contact W Box Tech Support 833-574-9124, email at info@wboxtech.com or the installing company

## Plug Producing Method

Instruments to be used: wire crimper, network tester and wire sequence of RJ45 plug should confirm with EIA/TIA568A or 568B

- 1 Please remove 0.79"(2cm) of the insulating layer and bare 8 pairs UTP cable
- 2 Separate the 8 pairs UTP cable and straighten
- 3 Line up the 8 pieces of cables per EIA TIA 568A or 568B
- 4 Cut off the cables to leave 0.6"(1.5cm) bare wire
- 5 Plug 8 cables into RJ45 plug make sure each cable is in each pin
- 6 Use the wire crimper to crimp
- 7 Repeat above steps to make additional ends
- 8 Use network tester to test the cable

Pin	Color
1	White/Green
2	Green
3	White/Orange
4	Blue
5	White/Blue
6	Orange
7	White/Brown
8	Brown



EIA/TIA 568A

Pin	Color
1	White/Orange
2	Orange
3	White/Green
4	Blue
5	White/Blue
6	Green
7	White/Brown
8	Brown



EIA/TIA 568B



### Notice

When choosing RJ45 connection type, make sure if one end is EIA/TIA568A then other end should also be EIA/TIA568A,

When choosing RJ45 connection type, make sure if one end is EIA/TIA568B, then other end should also be EIA/TIA568B,

## 1. Limited Warranty

### a. General

Subject to the terms and conditions of this Limited Warranty, from the date of sale through the period of time for product categories specified in Section 1(b), ADI warrants its W Box Technologies products to be free from defects in materials and workmanship under normal use and service, normal wear and tear excepted. Except as required by law, this Limited Warranty is only made to Buyer and may not be transferred to any third party.

ADI shall have no obligation under this Limited Warranty or otherwise if:

- (i) The product is improperly installed, applied or maintained;
- (ii) The product is installed outside of stated operating parameters, altered, or improperly services or repaired;
- (iii) Damage is caused by outside natural occurrences, such as lightning, power surges, fire, floods, acts of nature, or the like.
- (iv) Defects resulting from unauthorized modification, misuse, vandalism, or other causes unrelated to defective materials or workmanship, or failures related to batteries of any type used in connection with the products sold hereunder.

ADI only warrants those products branded as W Box Technologies products and sold by ADI. Any other products branded by third parties are warranted by the third party manufacturer for a period as defined by the third party manufacturer, and ADI assigns to Buyer those warranties and only those warranties extended by such third party manufacturers or vendors for non-ADI branded products. ADI does not itself warrant any non-ADI branded product and sells only on an as is basis in accordance with ADI's terms and conditions of sale.

### b. Specific Warranties for product categories are as follows:

Product Categories	Warranty Period
Walk Through & Hand Held Metal Detectors	12 months
Intrusion Wireless Communication Accessories	12 months
Smoke Detector Tester	12 months

CCTV Power Supplies	24 months
In Ceiling Speakers	24 months
Magnetic Locks	24 months
Surge Protection	24 months
UPS (uninterruptible power supplies)	24 months
HDMI Distribution	24 months
6 Outlet Surge Protection	24 months
Intrusion Audio Devices	30 months
Video Surveillance Monitors	30 months
Power and Relays	30 months
Hold-up Buttons	30 months
Video Surveillance Baluns	30 months
DVR's, NVR's	60 months excluding HDD; 36 months HDD (included in recorder)
HD Analog Cameras	60 months
IP Cameras	60 months
PIR's	60 months
Analog Cables	Limited Lifetime
B Connectors	Limited Lifetime
Bus Terminals	Limited Lifetime
Extension Cords	Limited Lifetime
HDMI Cables	Limited Lifetime
Jacks, Cords and Intrusion Communication Accessories	Limited Lifetime
Raceway Conduit	Limited Lifetime
Wire Ties	Limited Lifetime
Magnetic Contacts	Limited Lifetime
Network Switches/PoE Switches	Limited Lifetime